

# SZ20G

森

森

IP( =  
I /

9) .

(  
)

+

读 J8 J9

J7 J9

+

+

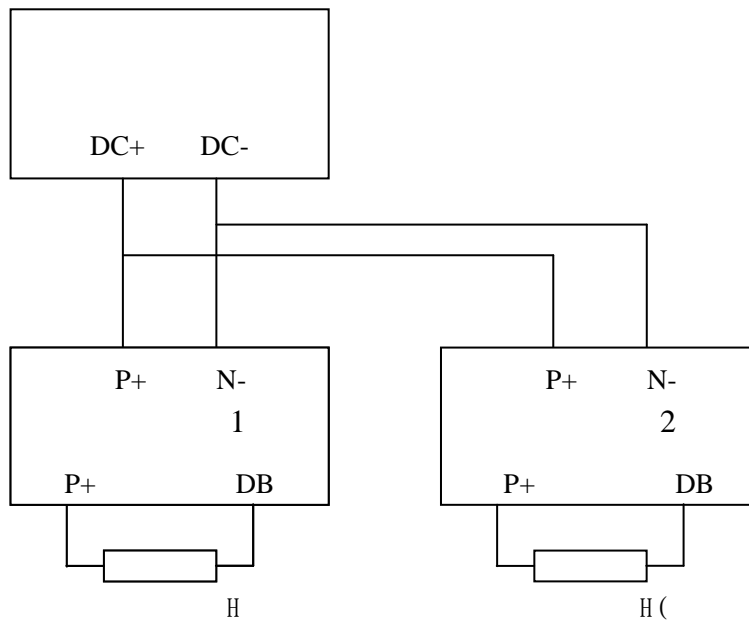
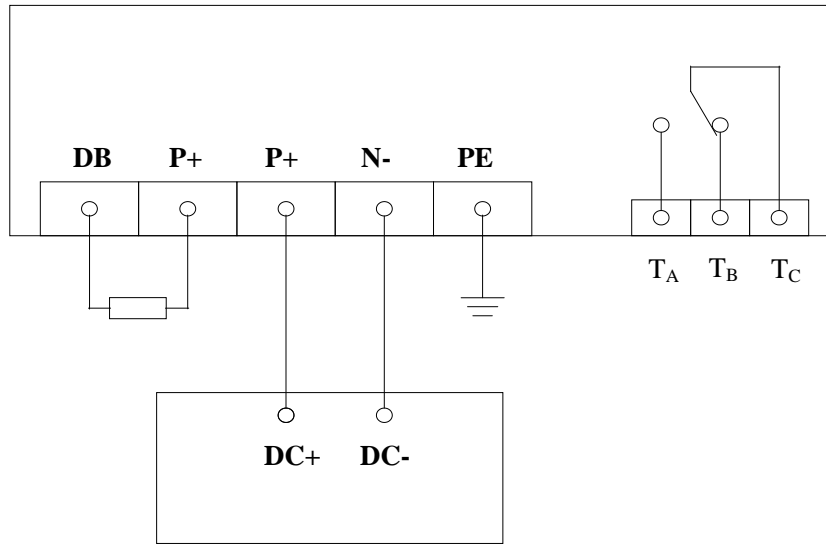

(

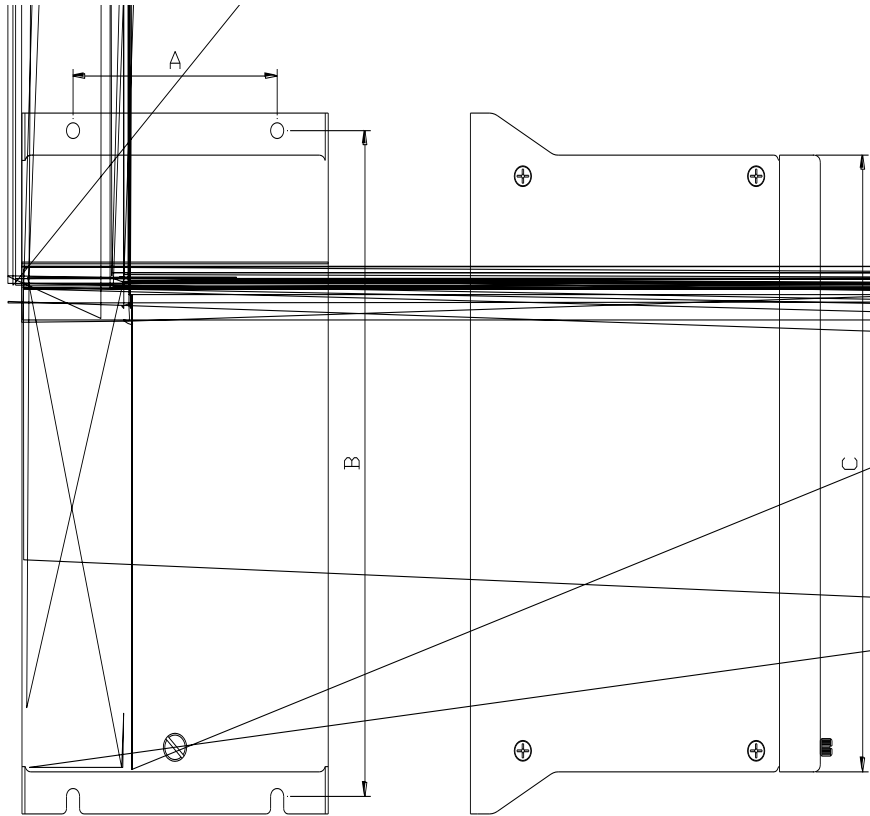
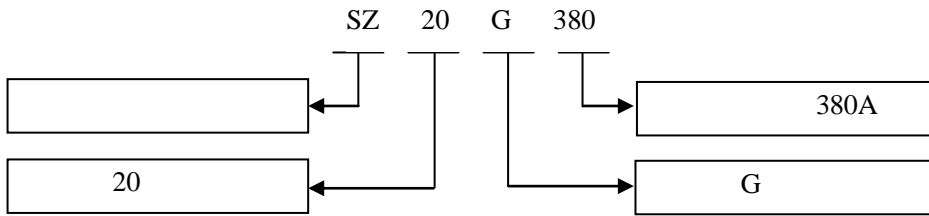

		aM		M				7	8	Z
IP ( = )	((	. +%( ( (	.	+	(	-	(	-	/	+
IP ( =		) %)-	.	(+	(	0		.	(.	++
IP ( =, +	.	+%++	.		)	( +	.	/	(.	++
IP ( = )	+ (	--+%/	.						(.	++
IP ( = -			.							
IP ( =(	(	) (%)	.	/ (	)	)	/+		) (-	+
IP ( =).	.	( % (+	.							

H d 3

H Wn3

(

! D

! 8

. - - (

-

H (.

H- ). 9

(